

Experimental Analysis of 360⁰ Rotation Wheels

Hombal P¹ Holey S² Chormale P³, Mali V⁴, Burute S⁵, Wagh K⁶

¹(Asst. Prof. Mechanical Engineering, JSPM Narhe Technical Campus, Narhe, Pune India)
^{2,3,4,5,6}(Student BE Mechanical Engineering, JSPM Narhe Technical Campus, Narhe, Pune, India)

Abstract: *The design and fabrication of 360 degree wheel rotation vehicle using DC motor and steering is done to reduce time to turn from one direction to other direction. This vehicle can move in all direction at a same position by use of RF transmitter-receiver principle, steering, sprocket, DC motor, bearing and chain drive. Main function of this vehicle is easy to rotate the wheels of vehicle in all 360 degree angle position. Modern development and economical progression of Indian society resulted in increase of people on railway platform; increase of vehicle on the road due to space constraints, in hospital is major problem of the country. Present study aims for development of a system to reduce the turning radius of vehicle. In this system at first vehicle is stopped and wheels are then turned in the required direction with help of steering system and DC motor. It has turning radius nearly equal to negligible of length of the vehicle itself. This vehicle used to carry the goods in various areas such as, railway platform, hospital, industries and market.*

Keywords: *DC Motors, RF transmitter, Bearing & chain drive, steering sprocket*

I. Introduction

This project is about design of 360 degree wheel rotating vehicle. This wheels of vehicle moves in all directions and this design provides better comfort and also saves the time of customers, most of the people using this vehicle to carry goods, patient etc. But most of the time, they have to face the problem like taking U turn etc. So have to design a 360 degree wheel rotating vehicle to reduce and eliminate problems in the industry and at the railway platform. Zero degree turning radius of a vehicle implies the vehicle rotating about an axis passing through the center of gravity of vehicle i.e. the vehicle turning at the same place, where it is standing. No extra space is required to turn the vehicle. So vehicle is to be turned in the space equal to the length of the vehicle itself. The DC motor is connected to wheels to run the vehicle. Our vehicle is rotate using WIFI operated in which RF transmitter receiver principle is used. All four wheels at one time rotated at 360 degree using buttons in the mobile application. So as a result this arrangement of the vehicle wheels to turn 90 degrees left and 90 degree right from original position, but front wheels of this vehicle rotate 360 degree by controlling wheels direction Without moving from the spot, i.e. the vehicle has zero turning radius. This helps in maneuvering the vehicle in tight spaces such as parking lots and within small compounds. The various functions of the wheel are to control the angular motion the wheels, direction of motion of the vehicle, to provide directional stability of the vehicle while going straight ahead, to facilitate straight ahead condition of the vehicle after completing a turn, the road irregularities must be damped to the maximum possible extent. This should co-exist with the road feel for the driver so that he can feel the road condition without experiencing the effects of moving over it.

The advanced new technology has led to various modifications in the automobile sector. Out of these, zero degree turning radius which is being analyzed in various vehicles e.g. hurricane jeep, JCB, Nano Pixel etc. The turning circle of a vehicle is the diameter described by the outside wheels when turning on full lock. There is no hard and fast formula to calculate the turning circle but it can be calculated using this; Turning circle radius = $(\text{track}/2) + (\text{wheelbase}/\sin(\text{average steer angle}))$. Zero degree turning radius of a vehicle implies the vehicle rotating about an axis passing through the center of gravity of vehicle i.e. the vehicle turning at the same place, where it is standing. No extra space is required to turn the vehicle. So vehicle can be turned in the space equal to the length of the vehicle itself. This technology exists in heavy earth movers like excavator which consists of two parts i.e. the upper part cabin and lower part crawler chain. The upper part of excavator can rotate about its center, so that the direction of cabin can be changed without changing direction of lower part. Conventional steering mechanism involves either the use of Ackerman or Davis steering systems. The disadvantage associated with these systems is the minimum turning radius that is possible for the steering action. This difficulty that is associated with the conventional methods of steering is eliminated by employing a four wheel steering system. In this system, the wheels connected to the front axles are turned opposite to each other, and so are the wheels connected to the rear axle. The wheels on the on left half vehicle rotate in one direction and the ones on the right half of the vehicle rotate in the opposite direction. This arrangement of the wheels enables the vehicle to turn 360 degrees, without moving from the spot, i.e. the vehicle has zero turning radiuses. This helps in maneuvering the vehicle in tight spaces such as parking lots and within small compounds. Automobile giants in India like Tata, Maruti, Hyundai, Honda, Ford, Mahindra and Mahindra etc. are

manufacturing more than 3 million vehicles per year. These companies are designing and producing varieties of models to fulfill the market competition and consumer satisfaction. The companies are emphasizing more about the ergonomics, aesthetic features, fuel economy, space available and many other features. It includes broadly power window, center lock, power brake system, power steering, tubeless tires, etc. In development of new cars, the major or minor improvements were made in every car's feature. Furthermore, manufacturing and servicing automobiles has become one of the biggest businesses. The designers endeavor to produce a vehicle, which will function at all times under all conditions and will be more comfortable to ride and easy to operate. Increased life of tires, independent front wheel suspension, four-wheel hydraulic brakes, high compression ratio, high power, use of new materials, hundreds of other changes have been made. In power steering, front wheel steering is made easier by means of hydraulic, electrical or pneumatic system. Power steering reduces efforts required for steering but can't reduce the turning circle radius of vehicle or the minimum space required for the turning of the car. Now-a-days peoples are preferring the bigger cars that are powerful, have better aesthetic and ergonomic features and easy to drive like Ford Icon, Maruti SX4, Tata Indigo, Honda City, Mercedes Benz, Volkswagens, Nissan etc..

The aim of this paper is to develop an alternative solution for conventional two wheel steering system. In modern era, the major characteristics of the vehicle like steer ability and handling have become major aspects. Conventional steering involve either the Ackerman or Davis steering system which has major disadvantage is it can't take minimum radius turn. Providing zero turn steering without any compromise in steer ability and handling of the vehicle is a major concern for automakers [1].

The type of steering system, uses of dc motors with switch board. With the help of switch board they control the direction of the wheels. There zero turn four wheel steering vehicle will move on power supply from an A.C. source. The switch board is a combination of two ways switches and ON/OFF switch. Now to give the constrained motion i.e. forward and reverse motion, we are using a set of two on and off switch and two way switches [2].

In standard 2 Wheel Steering System, the rear set of wheels are always directed forward and do not play an active role in controlling the steering. While in 4 Wheel Steering System, the rear wheels do play an active role for steering, which can be guided at high as well as low speeds [3].

Main function of car is to move from one place to another place. We find that every member of the family have their own vehicle. Car provides us lot of benefits like protect us from sun heat in summer and from rain in monsoon. Travelling is inevitable part of person's life Car is the most common thing in today's world. Having a car is the status in the society but having a costly car is a royal status in the society, with increase in number of vehicle people have to face traffic problems like parking [4].

Production cars are designed to under steer and rarely do they overseer. If a car could automatically compensate for an under steer/overseer problem, the driver would enjoy nearly neutral steering under varying operating conditions. Also in situations like low speed cornering, vehicle parking and driving in city conditions with heavy traffic in tight spaces, driving would be very difficult due to vehicle's larger wheelbase and track width. Hence there is a requirement of a mechanism which result in less turning radius and it can be achieved by implementing four wheel steering mechanism instead of regular two wheel steering. In this project Maruti Suzuki 800 is considered as a benchmark vehicle [5].

The front-to-rear wheel alignment plays a significant role in the directional stability of a vehicle in a good manner. Four wheel steering is the system that allows the rear wheels to turn for maneuvering, rather than just follow the front wheels. Apart from normal front wheel steered vehicle our designed model can work in all four modes of four wheel steering. The four modes include front wheel steering, This car has zero degree turning radius of a vehicle implies the vehicle rotating about an axis passing through the center of gravity of vehicle i.e. the vehicle turning at the same place, where it is standing [6].

The basic aim of steering is to ensure that the wheels are pointing in the desired directions. This is typically achieved by a series of linkages, rods, pivots and gears. One of the fundamental concepts is that of caster angle - each wheel is steered with a pivot point ahead of the wheel. In the paper they also explain the different types of steering system like 2 wheels, 4 Wheel Steering Systems, crab system etc. From these we found crab system more useful for the development of our project. [7].

The various functions of the steering wheel are, to control the angular motion the wheels, direction of motion of the vehicle, to provide directional stability of the vehicle while going straight ahead, to facilitate straight ahead condition of the vehicle after completing a turn, the road irregularities must be damped to the maximum possible extent. This project the use of steering is to rotate front wheels [8].

II. Construction & working:

A chassis consists of an internal framework that supports a manmade object in its construction and use. An example of a chassis is the under part of a motor vehicle, consisting of the frame. Four wheels are attached to the frame, which are driven by 30rpm DC motor. DC motors are used in each wheel to provide forward and

backward movement of this vehicle, also a battery is used to provide electrical energy of each DC motor. Here the amount of driving force is irrelevant as long as it is sufficient to overcome the wheels of the vehicle by 360 degree using remote. Transmitter receiver concept in electronics is used to control the rotation of vehicle. Remote of the vehicle consist of keypad by which we operate the vehicle. Transmitter is in the remote from which signals are transmitted to the receiver in the vehicle. The transmitter in remote send radio frequency of 433MHz by using encoder. Encoder is used to convert the frequency into digital format which is able to receive by the receiver. In receiver circuit in the vehicle consist of decoder which converts the digital frequency transmitted from the transmitter into analog frequency. This transmitted frequency is lost while transmitting. The frequency received by the receiver is given to the decoder & then to microcontroller. The signal is then passed to the DC driver which gives power to the motor.

III. Proposed Design of Chassis:

In the design procedure of the chassis and components we have used Catia software of modeling in which we considered all the design related parameters and designed model of required size and shape. The fixed frame forms the base of the 360 degree wheel rotation vehicle. This frame is made of Mild Steel (MS). It has four wheels attached to its two sides by sprocket bolt and square iron pipe. The shaft is selected by calculating the load to be lifted by it and various stresses acting on it.

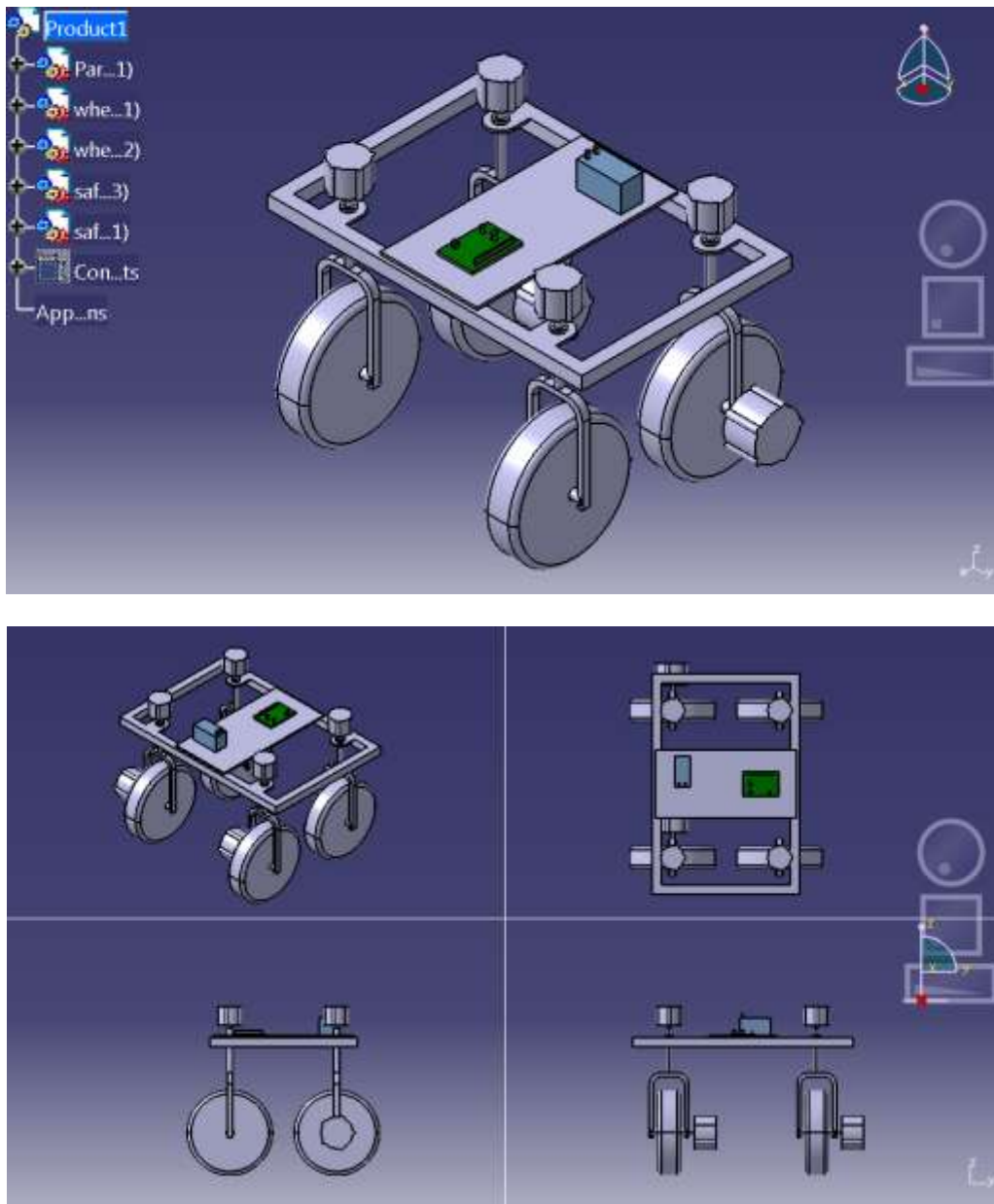

Fig 1: Proposed Design of Chassis

IV. Manufacturing Process

Raw materials: A raw material is the basic material used in the productions of the goods, finished products. The term “raw material” is used to denote material which is unprocessed.

Marking: Marking is the process of making visible impressions on the metal surface so that required operations can be carried out as per the dimensions

Cutting: The raw material cut into the required dimensions using a grinding wheel cutter. Metal cutting is done by a relative motion between the work and piece and the hard edge cutting tool, which is multi point cutting tool.

Welding: The assembly of base table is done by the process of welding. In this case the process is done by “Arc Welding”. Arc welding is type of welding that uses a welding power supply to create an electric arc between an electrode and the base material to melt the metal at the welding point. They can use either direct or alternating current, and consumable or non-consumable electrode.

Drilling: Drilling is easily the most common machining process. Drilling involves the creation of holes that are right circular cylinders. This is accomplished most typically by using the twist drill. The chips must exit through the flutes to the outside of the tool. The cutting front is embedded within the work piece, making cooling difficult. The cutting area can be flooded, coolant spray mist can be applied, or coolant can be delivered through the drill bit shaft.

Hand Grinding: Hand Grinding is the finishing process used to improve surface finish, abrade hard materials, and tighten the tolerance on the flat and cylindrical surface by removing the small amount of material. In grinding the abrasive material rubs against the metal part and removes the tiny pieces of material. The abrasive material is typically on the surface of the wheel.

V. Principle of Operation:

Batteries convert chemical energy directly to electrical energy. A battery consists of some number of voltaic cells. One half-cell includes electrolyte and the negative electrode, the electrode to which anions (negatively charged ions) migrate; the other half-cell includes electrolyte and the positive electrode to which cations (positively charged ions) migrate. Redox reactions power the battery. Cations are reduced (electrons are added) at the cathode during charging, while anions are oxidized (electrons are removed) at the anode during charging. During discharge, the process is reversed. The electrodes do not touch each other, but are electrically connected by the electrolyte. Some cells use different electrolytes for each half-cell. A separator allows ions to flow between half-cells, but prevents mixing of the electrolytes.

Each half-cell has an electromotive force (emf), determined by its ability to drive electric current from the interior to the exterior of the cell. The net emf of the cell is the difference between the emfs of its half-cells. Thus, if the electrodes have emfs ϵ_1 and ϵ_2 , then the net emf is $\epsilon_2 - \epsilon_1$; in other words, the net emf is the difference between the reduction potentials of the half-reactions. The electrical driving force or across the terminals of a cell is known as the *terminal voltage (difference)* and is measured in volts. The terminal voltage of a cell that is neither charging nor discharging is called the open-circuit voltage and equals the emf of the cell. Because of internal resistance, the terminal voltage of a cell that is discharging is smaller in magnitude than the open-circuit voltage and the terminal voltage of a cell that is charging exceeds the open-circuit voltage. An ideal cell has negligible internal resistance, so it would maintain a constant terminal voltage of ϵ until exhausted, then dropping to zero. If such a cell maintained 1.5 volts and stored a charge of one coulomb then on complete discharge it would perform 1.5 joules of work. In actual cells, the internal resistance increases under discharge and the open circuit voltage also decreases under discharge. If the voltage and resistance are plotted against time, the resulting graphs typically are a curve; the shape of the curve varies according to the chemistry and internal arrangement employed.

The voltage developed across a cell's terminals depends on the energy release of the chemical reactions of its electrodes and electrolyte. Alkaline and zinc–carbon cells have different chemistries, but approximately the same emf of 1.5 volts; likewise NiCd and NiMH cells have different chemistries, but approximately the same emf of 1.2 volts. The high electrochemical potential changes in the reactions of lithium compounds give lithium cells emfs of 3 volts or more.

5.1 Transmitter module:

An RF transmitter module is a small PCB sub-assembly capable of transmitting a radio wave and modulating that wave to carry data. Transmitter modules are usually implemented alongside a micro controller which will provide data to the module which can be transmitted. RF transmitters are usually subject to regulatory requirements which dictate the maximum allowable transmitter power output, harmonics, and band edge requirements.

The transmitter part consists of the keypad interfaced to the microcontroller. Any button number in decimal format is converted to 4 digit binary by the microcontroller and the parallel output at one of its port is

applied to the encoder. The encoder converts this parallel data to serial data and this is fed to the transmitter, fitted with an antenna to transmit the serial data.

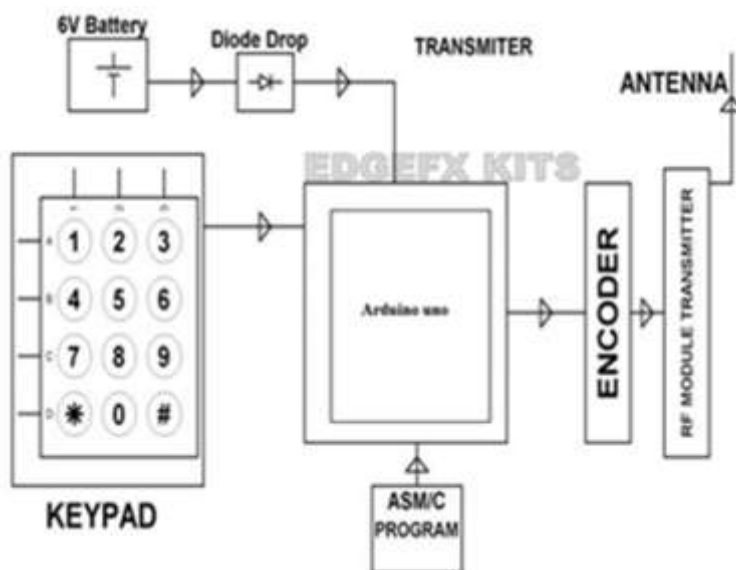

Fig. 2: Circuit diagram of transmitter

5.2 Receiver module:

An RF receiver module receives the modulated RF signal, and demodulates it. There are two types of RF receiver modules: super heterodyne receivers and super-regenerative receivers. Super-regenerative modules are usually low cost and low power designs using a series of amplifiers to extract modulated data from a carrier wave. Super-regenerative modules are generally imprecise as their frequency of operation varies considerably with temperature and power supply voltage. Super heterodyne receivers have a performance advantage over super-regenerative; they offer increased accuracy and stability over a large voltage and temperature range. This stability comes from a fixed crystal design which in the past tended to mean a comparatively more expensive product. However, advances in receiver chip design now mean that currently there is little price difference between super heterodyne and super-regenerative receiver modules. The receiver side consists of a decoder interfaced to the microcontroller. The decoder converts the received command in serial format to the parallel form and gives this data to the microcontroller. Based on this command the microcontroller sends the appropriate input signals to the motor drivers to drive the respective motors.

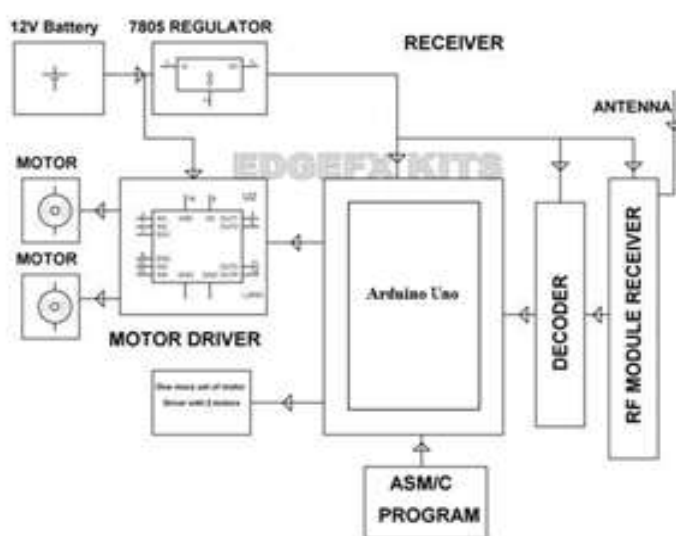

Fig. 3: Circuit diagram of receiver

6. FOUR MODES OF STEERING SYSTEM:

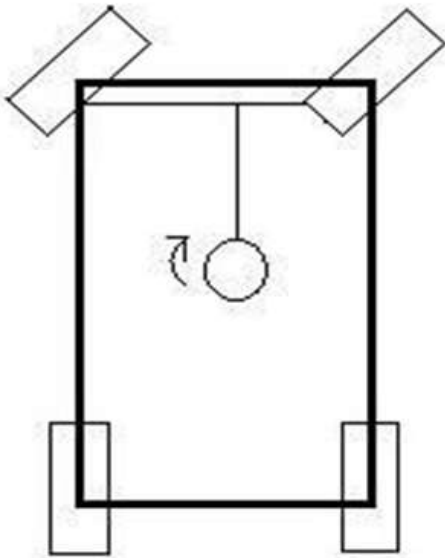

Figure 5: Front wheel turn

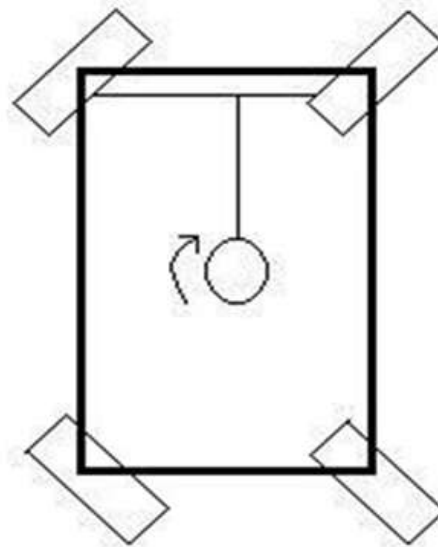

Figure 6: Short radius turn

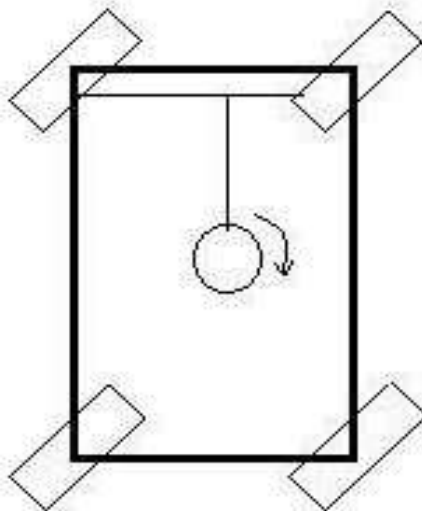

Figure 7: Parallel parking

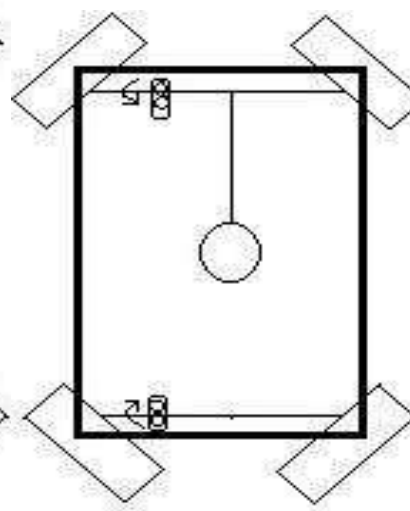

Figure 8: 360 degree turn

VI. Conclusion:

A prototype for the proposed approach was developed by DC motor to rotate the wheels in 360 degree. This prototype is found to be able to move and turn very easily in tight spaces, and after manufacturing of 360 degree wheel rotation vehicle consumed very less space to turn from one direction to another direction and it consumes less time to turn and this vehicle used in various areas such as small industries, railway platforms, parking areas, etc.

References:

- [1]. S. V. Shrisath, K. R. Jadhav, V.R. Patil, A.V Mohite, Prof. D.D Patil “Zero turn vehicle”, ISSN 2395 – 0056, Vol. 3,02 Feb 2016.
- [2]. K.Kozlowski, D.Pazderski “Modeling and control of four wheel skid steering mobile robot”,ISSN 477-495,Vol.14,2004
- [3]. Sanket Bhishikar, Vatsal Gudhka, Neel Dalal, Paarth Mehta, Sunil Bhil, A.C.Mehta,“Design and simulation of four wheel steering system”ISSN 2277-3754,Vol.3,ISSUE,12June-2014
- [4]. Sudip Kachhia,“Design the 360 degree rotating car”, ISSN 2395 – 4396, Vol. 2, May 2016.
- [5]. Dilip S Choudhari, “four wheel steering system for future”, ISSN 2278 – 0149, Vol. 3, No. 4, October 2014.
- [6]. Colin Varghese, David Babu, Delwin Kuriyakose, Harikrishnan discovers, “Different modes in four wheel steered multi- utility vehicles”, ISSN 2278 – 4721, Vol. 6, 4, April 2016.
- [7]. Vishnu Ashok, S. Arun Kumar, P. Gawtam, Akhil Raveendran, Anoop Thankachan, Roy Philip, “Design for 360° Rotating car”, ISSN 2319 – 8753, Vol. 7, on 04 April 2018.
- [8]. Er. Amitesh Kumar,Dr Dinesh M Kambale. “Zero Turn Four Wheel Steering system” ISSN 2229-5518,VOL 5,ISSUE 12 Dec14